

Science Practice Test 19
“More Practice” Answer Key

1. **C**

Assuming that the body is moving at a constant speed of 45 km/hr in a circular path, it experiences an acceleration that is directed towards the center of the circular path.

2. **B**

$$\text{Speed} = \frac{\text{distance}}{\text{time}} = \frac{\pi(2.0\text{m})^2}{2\text{s}} = \frac{4\pi\text{m}^2}{2\text{s}} = \frac{2\pi\text{m}^2}{\text{s}}$$

3. **D**

$$v = v_0^2 + at = 0 + \left(1.5 \frac{\text{m}}{\text{s}^2}\right)(20\text{s}) = 30 \frac{\text{m}}{\text{s}}$$

4. **C**

$$d = (v_i)(t) + \left(\frac{1}{2}\right)(a)(t^2)$$

$$20\text{m} = (0)(t) + \left(\frac{1}{2}\right)\left(1.5 \frac{\text{m}}{\text{s}^2}\right)(t^2)$$

$$20\text{m} = 0.75 t^2$$

$$t^2 = \frac{80}{3}$$

$$t = 5.164 \text{ seconds} \cong 5 \text{ seconds}$$

5. **D**

$$a = \frac{v^2}{r} = \frac{\left(2 \frac{\text{m}}{\text{s}}\right)^2}{0.2 \text{ m}} = 20.0 \text{ m/s}^2$$

6. **D**

$$V_f = V_i + at$$

$$V_f = 50 \frac{\text{m}}{\text{s}} + \left(2 \frac{\text{m}}{\text{s}^2}\right)(10 \text{ s})$$

$$V_f = 50 \text{ m/s} + 20 \frac{\text{m}}{\text{s}} = 70 \frac{\text{m}}{\text{s}}$$

7. **C**

$$\text{Power} = \frac{\text{Work}}{\text{time}} = \frac{(\text{Force})(\text{distance})}{\text{time}}$$

$$\text{Power} = \frac{(\text{mass})(\text{acceleration})(\text{distance})}{\text{time}}$$

$$a = \frac{V_f - V_i}{t} = \frac{6 \frac{\text{m}}{\text{s}} - 3 \frac{\text{m}}{\text{s}}}{2.0 \text{ s}} = 1.5 \frac{\text{m}}{\text{s}^2}$$

$$S = \text{distance} = V_i t + \frac{1}{2} at^2$$

$$S = \left(3 \frac{\text{m}}{\text{s}}\right)(2.0 \text{ s}) + \frac{1}{2} \left(1.5 \frac{\text{m}}{\text{s}^2}\right)(2.0 \text{ s})^2$$

$$S = 6 \text{ m} + 3 \text{ m} = 9 \text{ m}$$

$$\text{Power} = \frac{(\text{mass})(\text{acceleration})(\text{distance})}{\text{time}}$$

$$\text{Power} = \frac{(40.0 \text{ kg})\left(1.5 \frac{\text{m}}{\text{s}^2}\right)(9 \text{ m})}{2 \text{ s}} = 270 \text{ Watts}$$

8. **B**

$$V_f = V_i + at$$

$$t = \frac{V_f - V_i}{a} = \frac{14.75 \frac{\text{m}}{\text{s}} - 2 \frac{\text{m}}{\text{s}}}{1.5 \frac{\text{m}}{\text{s}^2}} = 8.5 \text{ s}$$

9. **B**

He had a total travel time of 1 ½ hours.

So, 1.5 hours x 35 kph = 52.5 km

10. **D**

A body that moves in a circular path at constant speed has an acceleration directed towards the center of the circle, called centripetal acceleration.

11. **A**

The acceleration of an object is greatest when all the forces acting on it are in the same direction. This is because the forces add together which results in a larger net force. According to Newton's second law ($F=ma$), a greater net force produces a greater acceleration for the same mass.

12. **C**

Downstream speed = 30 km / 2 hr = 15km/hr

Upstream speed = 30 km / 3 hr = 10km/hr

Speed in still water = $\frac{(15 \frac{\text{km}}{\text{hr}} + 10 \frac{\text{km}}{\text{hr}})}{2} = 12.5 \text{ km/hr}$

13. **D**

During constant acceleration, the graph increases linearly. During constant velocity, the velocity stays the same.

14. C

Suppose that the forces acting on a hockey puck are 5.0 N at 30° **W of S** and 12.0 N of **W**. What is the acceleration of the puck, given that its mass is 0.1 kg.

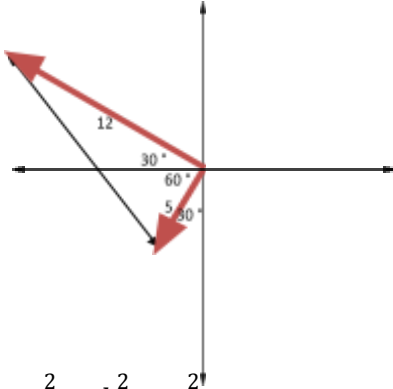

$$a^2 + b^2 = c^2$$

$$(5)^2 + (12)^2 = c^2$$

$$c^2 = 169$$

$$c = 13 \text{ N}$$

$$F = ma$$

$$a = \frac{\text{Force}}{\text{mass}} = \frac{13 \text{ N}}{0.1 \text{ kg}} = 130 \frac{\text{m}}{\text{s}^2}$$

15. B

Speed is a scalar quantity which describes the magnitude only. In contrast, velocity is a vector quantity which describes both magnitude and direction. Since, the direction is indicated in the problem, the speed should be changed to velocity.

16. B

The air resistance will slow down and decrease the acceleration of an object undergoing free fall. The velocity versus time graph will show velocity approaching a constant value implying a decreasing acceleration.

Science Practice Test 20
“More Practice” Answer Key

1. **C**

Let x be the number of hours the girl travelled at 40 mph

$5-x$ be the number of hours the girl travelled at 60mph

$$40mph(x \text{ hrs}) + 60mph(5 - x \text{ hrs}) = 240$$

$$40x + 300 - 60x = 240$$

$$-20x = -60$$

$$x = 3$$

2. **B**

$$Force_{left} = Force_{right}$$

$$Force = (mass)(distance)$$

$$(Mass)(4m + 2m) + (3kg)(2m) = (10kg)(3m)$$

$$Mass(6m) + 6N = 30N$$

$$Mass(6m) = 24N$$

$$Mass = 4kg$$

3. **D**

Levers can amplify a small input force to a greater output force. For example, a large force over a short distance at one end of the lever can be lifted by a smaller force over a longer distance at another end of the lever. Thus, in this specific example, if the ball is nearer to the fulcrum, then less force is to be applied to lift the ball.

4. **D**

When a composite light (such as white light) passes through a transparent medium (such as a prism), light refracts and forms the seven colors of the visible spectrum.

5. **D**

$$KE = \frac{1}{2} mv^2$$

Let M be the new value for KE after the variables m and v are changed.

a. If mass is halved

$$M = \frac{1}{2} \left(\frac{1}{2} m \right) (v^2) = \frac{1}{4} mv^2 = \frac{1}{2} KE$$

b. If mass is doubled

$$M = \frac{1}{2} (2m) (v^2) = mv^2 = 2KE$$

c. If velocity is halved

$$M = \frac{1}{2} (m) \left(\frac{1}{2} v \right)^2 = \frac{1}{8} mv^2 = \frac{1}{4} KE$$

d. If velocity is doubled

$$M = \frac{1}{2} (m) (2v)^2 = 4KE$$

6. **D**

$$distance_x = \left(3 \frac{m}{s} \right) (1.5 \text{ seconds}) = 4.5 m$$

7. **A**

$$distance_y = (v_i)(t) + \left(\frac{1}{2} \right) (a)(t^2)$$

$$5 m = (0)(t) + \left(\frac{1}{2} \right) \left(10 \frac{m}{s} \right) (t)^2$$

$$5 m = 5t^2$$

$$t^2 = 1$$

$$t = 1.0 \text{ second}$$

8. **C**

$$S = V_i t + \frac{1}{2} at^2 = 0 + \frac{1}{2} (10 m/s^2) (4 s)^2$$

$$S = 80 \text{ meters}$$

9. **C**

Given:

$$V_f \text{ at the top} = 0 \text{ m/s}$$

$$V_i = 4 \text{ m/s}$$

$$V_f^2 = V_i^2 + 2a\Delta d$$

$$0 = (4)^2 + 2(-9.8)$$

$$0 = 16 - 19.6d$$

$$19.6d = 16$$

$$d = \frac{16}{19.6} = 0.82 \text{ m}$$

10. A

$$\frac{F}{m} = a = \frac{50\,000\text{ N}}{500\text{ kg}} = 100 \frac{\text{m}}{\text{s}^2}$$

11. D

To be able to lift an object, you must apply a force that can overcome the force of gravity.

$$F = ma = (5\text{ kg})\left(10 \frac{\text{m}}{\text{s}^2}\right) = 50\text{ N}$$

12. C

$$KE = \frac{1}{2}mv^2 = \frac{1}{2}(0.5\text{ kg})\left(2 \frac{\text{m}}{\text{s}}\right)^2 = 1\text{ J}$$

13. A

$$PE = mgh$$

$$10\text{ J} = (2\text{ kg})\left(10 \frac{\text{m}}{\text{s}^2}\right)(h)$$

$$h = \frac{10\text{ J}}{(2\text{ kg})\left(10 \frac{\text{m}}{\text{s}^2}\right)} = 0.5\text{ m}$$

14. C

$$500\text{ mg} = 0.5\text{ kg}$$

$$\frac{F}{m} = a = \frac{300.0\text{ N}}{0.5\text{ kg}} = 600 \frac{\text{m}}{\text{s}^2}$$

$$V_f = V_i + at = 0 + \left(600 \frac{\text{m}}{\text{s}^2}\right)(0.1\text{ s})$$

$$V_f = 60 \frac{\text{m}}{\text{s}}$$

15. A

$$KE = \frac{1}{2}mv^2$$

Let K be the new value of KE after the variables m and v are changed

$$\begin{aligned} K &= \frac{1}{2}\left(\frac{1}{2}m\right)(2v)^2 = \frac{1}{2}\left(\frac{1}{2}\right)(m)(4)(v^2) \\ &= 2\left(\frac{1}{2}mv^2\right) = 2KE \end{aligned}$$

Thus, if the mass of a body is halved and the velocity is doubled, its kinetic energy will double.

16. C

A falling object is losing height, thus, losing potential energy, while gaining acceleration. As it gains acceleration, its velocity also increases. So the kinetic energy also increases.

17. C

At point C, all of the potential energy of the system has been converted to its kinetic energy. Since kinetic energy is dependent on velocity, point C has the highest velocity. Thus, this is the point with the fastest flow.

18. B

Refraction is the bending of light as it passes from one medium to another. For example, when a pencil is placed in water (see image below), it appears bent. This happens because light changes speed when it moves from air to water, causing it to change direction.



Source: <https://ingenium.ca/en/learn/science-at-home/broken-pencil-illusion/>

19. C

$$d = 8.45\text{ m}$$

$$d_2 = 6.05\text{ m}$$

$$\frac{a}{g} = 10 \frac{\text{m}}{\text{s}^2}$$

$$V_1 = 0 \frac{\text{m}}{\text{s}} \text{ (velocity at the height)}$$

$$V_f^2 = V_i^2 + 2ad$$

$$V_f = \sqrt{2ad}$$

$$V_f = \sqrt{2\left(10 \frac{\text{m}}{\text{s}^2}\right)(8.45\text{ m})}$$

$$V_f = \sqrt{169 \frac{\text{m}^2}{\text{s}^2}}$$

$$V_f = 13 \frac{\text{m}}{\text{s}}$$

20. B

$$V_f = \sqrt{2ad}$$

$$V_f = \sqrt{2 \left(10 \frac{m}{s^2}\right) (6.05m)}$$

$$V_f = \sqrt{121 \frac{m^2}{s^2}}$$

$$V_f = 11 \frac{m}{s}$$

21. C.

$$\Delta\alpha \text{ (change in acceleration)} = \frac{\Delta v}{\Delta t}$$

$$\Delta\alpha = \frac{V_{FINAL} - V_{INITIAL}}{\Delta t}$$

$$\Delta\alpha = \frac{(11 - (-13))}{0.05 s} \quad * 0.05 \text{ to fraction is } \frac{1}{20}$$

$$\Delta\alpha = \frac{24 m/s}{\frac{1}{20} s} = 480 \frac{m}{s^2}$$

22. A

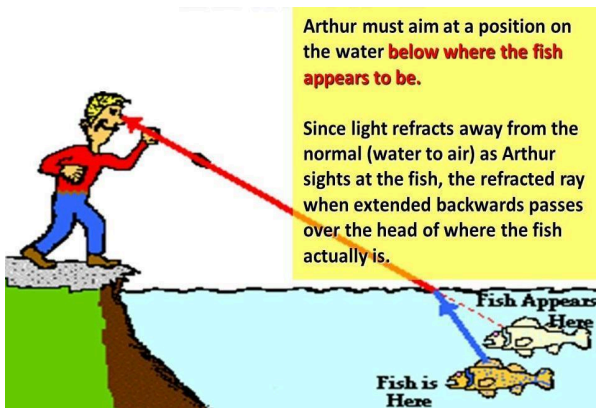

Source: https://images.slideplayer.com/29/9482833/slides/slide_8.jpg

23. B.

The potential energy (PE = mgh) depends on the height. In a parabola, the maximum height is where the highest PE is.

24. C.

In Hooke's Law for elastic materials: Stress is directly proportional to strain. If you increase stress, strain also increases proportionally.

25. A

Potential energy is stored energy that increases as height increases. Kinetic energy is the energy of motion and increases as velocity increases.

As the skateboard goes down the ramp, its kinetic energy increases because its velocity increases due to acceleration caused by gravity. Meanwhile, its potential energy decreases as its height decreases.

26. B

The reflected ray and the incident ray are on opposite sides of the normal line.

27. D

When you lift an object, the work done is equal to the potential energy gained in doing so. Thus, work is equal to the gravitational PE.

$$\text{Work}_{\text{vertical}} = mgh$$

$$\text{Work}_{\text{vertical}} = 5 \text{ kg} \times 9.8 \text{ m/s}^2 \times 4 \text{ m} = 196 \text{ J}$$

$$\text{Work} = \text{force} \times \text{distance}$$

$$\text{Work}_{\text{horizontal}} = 20 \text{ N} \times 3 \text{ m} = 60 \text{ J}$$

$$\text{Work}_{\text{Total}} = 196 \text{ J} + 60 \text{ J} = 256 \text{ J}$$

28. A

The lower the position, the greater the kinetic energy.

In terms of kinetic energy:

$$A < D=B < F < E < C$$

29. A

Basing on the Newton's Second Law of Motion, given the same amount of force, a body with less mass will have a higher acceleration.

30. C

A lever must satisfy the equation $w_1d_1 = w_2d_2$. To get w_2 ,

$$w_2 = w_1d_1/d_2 = (200\text{N})(3\text{m})/(1.5\text{m}) = 400 \text{ N}$$

31. C

Due to the Law of Inertia, the sleeping passenger will resist the acceleration and try to stay at rest. So, when the bus moves forward, the sleeping passenger will move backward to resist the change in motion.

32. B

$$W = F \times d = 1000 \text{ N} \times 4 \text{ m} = 4000 \text{ J}$$

33. A

$$P = W/s = 4000 \text{ J} / 5\text{s} = 800 \text{ Watts}$$

34. D

The same magnitude of force at the opposite direction must be applied to stop the box.

35. B

$$F = ma ; a = v/t$$

$$F = \frac{mv}{t}$$

$$t = \frac{mv}{F}$$

$$t = \frac{5 \text{ kg} \times 2 \text{ m/s}}{10 \text{ N}}$$

$$t = 1 \text{ second}$$

36. C

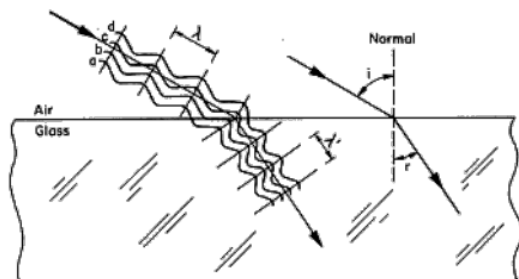

Source: <https://www.asu.edu/courses/phs208/pattemsb/PiN/rdg/refraction/figure3.gif>

Refraction is an effect that occurs when a light wave, incident at an angle away from the normal, passes a boundary from one medium into another in which there is a change in velocity of the light. Light is refracted when it crosses the interface

from air into glass in which it moves more slowly. Since the light speed changes at the interface, the wavelength of the light must change, too. The wavelength decreases as the light enters the medium and the light wave changes direction.

37. A

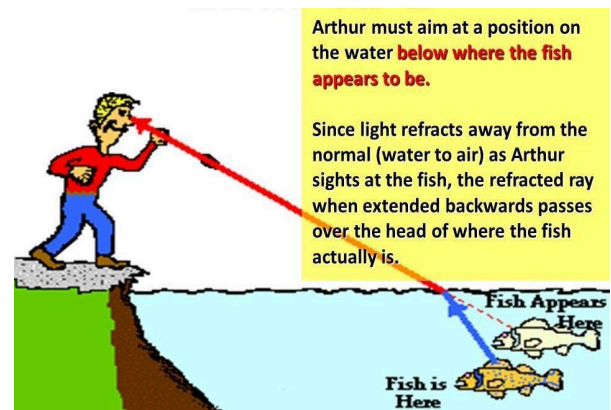

Source: https://images.slideplayer.com/29/9482833/slides/slide_8.jpg

Science Practice Test 21
“More Practice” Answer Key

1. **C**

Weight is the downward pull of Earth’s gravity on any object.

2. **D**

$$Work = (Force)(Distance_{\perp})$$

Thus, there is no work done on an object if it doesn’t move in a motion that is perpendicular from gravity.

If a cart is pushed a certain distance, then it moves at the surface of the Earth which is perpendicular from the pull of gravity.

Carrying a briefcase while going upstairs and climbing a mountain with a backpack involves moving in a diagonal motion, which consists of a vertical and a horizontal component. Thus, work is done in the first three examples.

The force exerted by a person’s head to a basket placed on top of it is upwards. This force is parallel to the pull of gravity. Thus, there is no work exerted by the head to the basket.

3. **D**

Since $Potential\ Energy = mgh$, then, as a bullet goes straight upwards, its height above the ground increases, and thus, its potential energy increases.

4. **C**

Given that $Work = (Force)(Distance_{\perp})$, the only possibilities wherein no work is accomplished is when force was not exerted or if there is no motion that is perpendicular from the pull of gravity. Pushing against wall does not produce motion and thus, it has no work.

5. **A**

According to Ohm's Law, electric current is directly proportional to the applied voltage and is inversely proportional to the resistance due to

connected devices ($V = IR$). Thus if resistance is doubled, current should be halved.

6. **C**

Since $momentum = (mass)(velocity)$, we can say that it is a vector quantity. For a system to have a net momentum of $+12 \frac{kgm}{s}$, the movement should be to the right. This eliminates choices a, b and d. System A doesn’t have a net momentum since the similar balls move in the same speed at different directions. Both systems A and B have negative momenta since its movement is to the left.

7. **D**

There are a lot of forces acting on the box like the normal force and weight. But these forces are cancelling each other out, that is why the box is not moving.

8. **B**

The Law of Acceleration states that the acceleration of an object increases when the force applied is high or the mass of the object is low, thus:

$$a = \frac{force}{area}$$
$$a = \frac{50kg\ m/s^2}{5\ kg}$$
$$a = 10\ m/s^2$$

9. **D**

$$T = r \cdot F (\sin\Theta)$$

Torque is maximum when $\Theta=90^\circ$, meaning the force is perpendicular to the wrench.

10. **B**

The formula $F\Delta t = m \Delta v$ shows the impulse-momentum theorem. It helps determine the change in velocity of the car during a crash by relating the force applied, the time of impact, and the mass of the car.

11. **A**

The formula of the thermal (heat) efficiency is:
Heat (thermal) efficiency is calculated using:

$$\text{Efficiency} = \frac{\text{Work Output}}{\text{Heat input}} \times 100\%$$

$$\text{Efficiency} = \frac{1000J}{10000J} \times 100\% = 0.1 \times 100\%$$

$$\text{Efficiency} = 10\%$$

12. **A**

$$\text{Efficiency} = \frac{\text{Output}}{\text{Input}} \times 100\%$$

$$\text{Efficiency} = \frac{150J}{500J} \times 100\% = 0.3 \times 100\%$$

$$\text{Efficiency} = 30\%$$

13. **B**

In a perfectly elastic collision, both momentum and kinetic energy are conserved.

Thus, when a heavier particle collides with a lighter one, the lighter particle tends to bounce away faster, while the heavier one loses some of its speed. This happens because the lighter particle is easier to accelerate, so it gains more speed from the collision, while the heavier particle slows down.

14. **A**

Energy is power multiplied by time.

Considering the equal length of time, the appliance with the lowest power requirement will give the least amount of energy use.

15. **B**

16. **C**

Momentum = mv

Body	Mass (kg)	Velocity (m/s)	Momentum (kg m/s)
A	1	5	5
B	2	4	8
C	3	3	9
D	4	2	8

17. **B**

KE = $\frac{1}{2}mv^2$

Body	Mass (kg)	Velocity (m/s)	KE (J)
A	1	5	12.5
B	2	4	16
C	3	3	13.5
D	4	2	8

Science Practice Test 22
“More Practice” Answer Key

1. **B**

If the strings of a guitar are plucked harder, then the vibrations that accompany the plucking will contain more (sound) energy.

2. **D**

A short circuit is a failure in an electric circuit caused by excessive flow of current due to negligible (or no) resistance.

3. **D**

$$\text{Voltage}_{total} = 1V + 3V + 4V = 8 \text{ volts}$$

4. **A**

A wavelength is the distance between two points on neighboring waves that are in the same phase (For example: crest to crest or trough to trough).

5. **B**

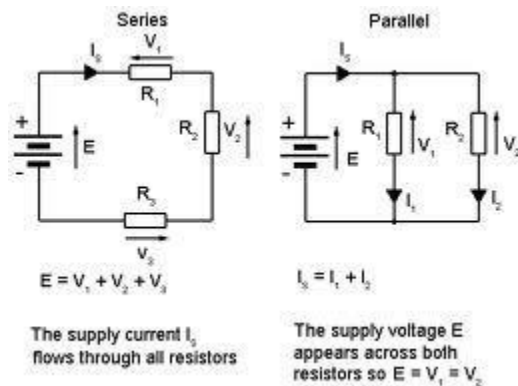

Source:http://www.learnabout-electronics.org/resistors_20.php

In a parallel circuit, devices are attached in such a way to allow all positive poles to be connected to one conductor and all negative ones to another conductor. So, if one device is removed or defective, all other devices are still connected to the conductors and that current still flows to each one of it.

6. **A**

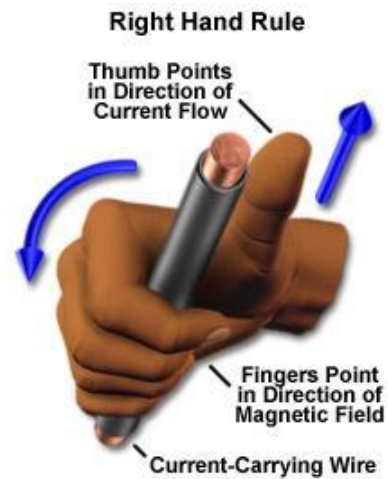

Source:<http://www.magnet.fsu.edu/education/tutorials/java/handrules/>

According to the right-hand-rule, if you point your thumb to the current, and assume your fingers in a curved position, then your fingers will show the direction of magnetic field. Since current in electrical circuit flows in a linear motion, then the magnetic field is in a circular shape.

7. **C**

According to Ohm's Law, $V = IR$. Thus, if a device has high resistance, it will receive a low current.

8. **C**

Opposite charges attract while like charges repel. Thus, if both balls have a positive charge, they will repel each other. Since they exert the same repulsive force to each other, each ball will have the same displacement from its original position.

9. **B**

The pitch of guitar strings represents the frequency of the sound wave produced by the strings. A higher pitch is produced by high-frequency sound waves. The frequency of a stretched wire depends on three factors which, combined in a single formula, is found to be

$$f = \frac{1}{2L} \sqrt{\frac{T}{m}}$$

where f is the frequency, L is the length, T is the tension and M is the mass per unit length (linear density)

From the formula, we can see that the frequency is proportional to tension and is inversely proportional to length and to mass per unit length. Thus, an object with a high pitch must be tight, short and has a low linear density. Assuming that the strings are made of the same material, a thin wire has a lower linear density than that of a thick wire.

10. **D**

Voltage = (Current)(Resistance)

$$V = IR$$

$$I = \frac{V}{R}$$

Current is inversely proportional to resistance. Thus, least current will be used in the object with the greatest resistance, which is the television.

11. **D**

12. **D**

Power = (Voltage)(Current)

Voltage = (Current)(Resistance)

Power = (Current)²(Resistance)

$$P = I^2R = (3.0 \text{ A})^2(400.0 \text{ } \Omega) = 3600 \text{ Watts}$$

13. **B**

Given the formula $V=IR$, resistance and voltage have a direct relationship. Thus, if the resistance is doubled, the voltage also doubles.

14. **D**

- Wavelength and pitch are inversely proportional.
- Amplitude determines the loudness or softness of sound waves.
- Amplitude does not affect the pitch. Instead, it affects the volume of sound

15. **D**

According to Plank's quantum theory:

$$E = hf \text{ or } E = hc/\lambda$$

Where,

E = photon energy

h = Planck's constant

f = The electromagnetic frequency measured in Hertz or Hz

Hence, the energy of photon is inversely proportional to wavelength.

16. **B**

The bulb in circuit X receives the full voltage of the battery.

Circuit I:

The voltage will be divided in the two bulbs in series. Circuit I is dimmer than Circuit X.

Circuit II:

If each battery has 1V, the total voltage of the three batteries in series is 3V. The two bulbs in series will divide the 3V. Each bulb gets 1.5V. Therefore, the bulbs in circuit II are brighter than Circuit X.

Circuit III:

If each battery has 1V, the total voltage of the two batteries in series is 2V. The three bulbs in series will divide the 2V. Each bulb gets $\frac{2}{3}$ V. Therefore, the bulbs in circuit III are dimmer than Circuit X.

Circuit IV:

There is one battery and two bulbs in series. Each bulb receives full voltage just like if it were alone. This circuit glow as bright as circuit X.

Circuit V:

Two batteries are in parallel, so the total voltage will only be 1V. The bulbs in series will divide the voltage. Circuit V is dimmer than circuit X.

17. A

Wavelength and energy are inversely proportional.

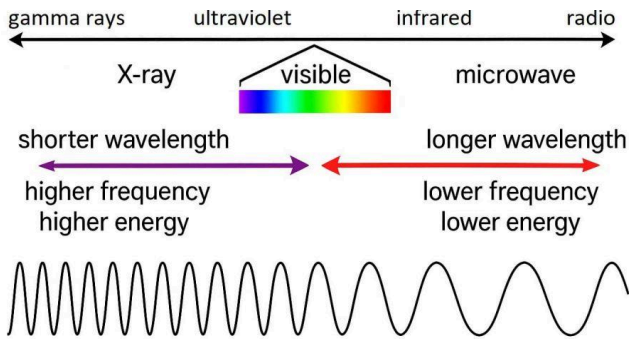

18. A

- A. true
- B. A bar magnet has two poles.
- C. Only moving charges produce magnetic fields.
- D. Magnetic poles cannot be separated by cutting the magnet.

19. D

The photoelectric effect shows that light behaves as a particle rather than a wave.

20. D

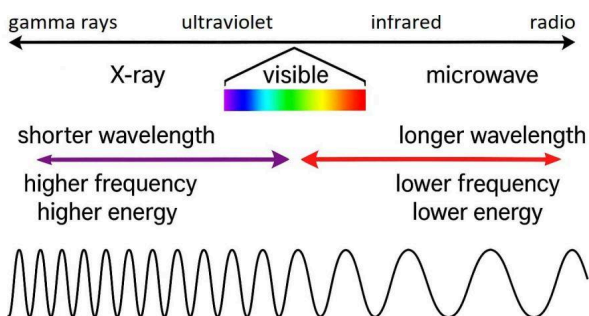

Radio waves have the longest wavelength while gamma rays have the shortest wavelength.

21. A

The shorter the wavelength, the higher the energy.

22. C

Violet has the highest energy since it has the shortest wavelength.

23. D

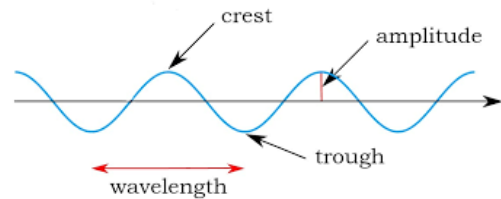

Source: <https://quantumphysicslady.org/glossary/wavelength/>

Wavelengths are measured from 1 peak to another peak (crest to crest or trough to trough).

24. D

Period is the amount of time it takes for one cycle to complete. Frequency is a measurement of how many cycles can happen in a certain amount of time. Wavelength is defined as the distance from a particular height on the wave to the next spot on the wave where it is at the same height and going in the same direction. Amplitude is a measure of how big the wave is.

25. B

The voltage in a parallel circuit is just the same.

Science Practice Test 23
“More Practice” Answer Key

1. **C**

$$R_{total} = 1\Omega + 1\Omega + R_{parallel}$$

$$3 = 1\Omega + 1\Omega + R_{parallel}$$

$$R_{parallel} = 1\Omega$$

$$\frac{1}{R_{parallel}} = \frac{1}{2\Omega} + \frac{1}{R}$$

$$\frac{1}{1\Omega} = \frac{1}{2\Omega} + \frac{1}{R}$$

$$1 = \frac{1}{2} + \frac{1}{R}$$

$$\frac{1}{R} = \frac{1}{2}$$

$$R = 2$$

2. **B**

Everything falls at a constant acceleration of g (9.8 m/s^2). However, some other factors affect this acceleration. Raindrops fall at the atmosphere, specifically, at the thermosphere. This means that it is exposed to air resistance. After some time, the force caused by gravity will be balanced out by the force due to air resistance. Thus, the raindrops will fall at a constant speed.

3. **B**

4. **B**

In a parallel circuit, $\frac{1}{R_T} = \frac{1}{R_1} + \frac{1}{R_2}$.

$$\frac{1}{R_T} = \frac{1}{20\Omega} + \frac{1}{50\Omega} = \frac{7}{100\Omega}$$

$$R_T = \frac{100}{7}\Omega \approx 14\Omega$$

5. **A**

Pressure depends upon the height of the liquid. Since water in glass A has the highest height, this exerts the greatest pressure.

6. **C**

$$P=I^2R$$

$$P=2^2(25)=100 \text{ watts}$$

7. **B**

Alpha radiation can be stopped by using a piece of paper.

8. **B**

Total resistance of parallel:

$$\frac{1}{R_T} = \frac{1}{R_1} + \frac{1}{R_2} + \frac{1}{R_3}$$

$$\frac{1}{R_T} = \frac{1}{2\Omega} + \frac{1}{3\Omega} + \frac{1}{4\Omega}$$

$$\frac{1}{R_T} = \frac{6+4+3}{12\Omega}$$

$$\frac{1}{R_T} = \frac{13}{12\Omega}$$

$$R_T = \frac{12\Omega}{13\Omega}$$

9. **C**

a. $R_T(\text{series}) = 2\Omega + 2\Omega + 2\Omega \text{ RT} = 6\Omega$

b. $\frac{1}{RT}(\text{parallel}) = \frac{1}{2}\Omega + \frac{1}{3}\Omega + \frac{1}{4}\Omega$

$$\frac{1}{RT} = \frac{3}{2\Omega}$$

$$R_T(\text{parallel}) = \frac{2}{3\Omega}$$

c. $R_T(\text{series}) = 2\Omega + 2\Omega = 4\Omega$

$$\frac{1}{RT} = \frac{1}{4\Omega} + \frac{1}{2\Omega}$$

$$\frac{1}{RT} = \frac{1+2}{4\Omega}$$

$$\frac{1}{RT} = \frac{3}{4\Omega}$$

$$R_T(\text{series}) = \frac{4\Omega}{3}$$

10. **C**

$$N_1 = 300 \text{ turns}$$

$$V_1 = 150 \text{ V}$$

$$N_2 = 600$$

$$V_2 = \text{unknown}$$

$$\frac{N_1}{V_1} = \frac{N_2}{V_2}$$

$$V_2 = \frac{N_2 V_1}{N_1}$$

$$V_2 = \frac{600 \times 150 \text{ V}}{300}$$

$$V_2 = 300 \text{ V}$$

$$V = IR$$

$$I = \frac{V}{R}$$

$$P = IV$$

$$P = \frac{V}{R} \cdot V$$

$$P = \frac{V^2}{R}$$

$$P = \frac{(300 V)^2}{90\Omega}$$

$$P = \frac{90000}{90}$$

$$P = 1000 W$$

11. C

mass = density x volume

The total volume displaced by the 50 candies is 3 mL.

Volume displaced = 8.25 mL - 5.25 mL = 3 mL

Get the mass of 50 candies.

mass = 9.28 g/ml x 3 ml

Divide this by 50 to get the mass of one mentos candy.

Thus, the equation is:

$$\frac{8.25 \text{ mL} - 5.35 \text{ mL} \times 9.28 \text{ g/ml}}{50}$$

12. D

$$Q = k \frac{Q_1 Q_2}{r^2}$$

$$Q_3 = \frac{Q_1 Q_3}{4}$$

$$Q_3 = \frac{Q_2 Q_3}{1}$$

$$\frac{Q_1 Q_3}{4} = \frac{Q_2 Q_3}{1}$$

$$\frac{Q_1}{4} = \frac{Q_2}{1}$$

$$Q_1 = 4Q_2$$

13. B

$$g = Gm/r^2$$

If mass is constant and G being the universal gravitational acceleration, if the radius is halved, the gravitational acceleration will four times the original. Since weight is equal to mass times acceleration, the weight of an object will also be four times the original. Therefore, IV is true.

$$F = Gm_1 m_2 / r^2$$

With radius halved and the masses constant, the gravitational force/ gravitational pull will also increase by four times. Therefore, III is true. Density is mass divided by volume. With volume being halved and mass constant, the density will be twice the original.